

EFR-9180

600-1000HP

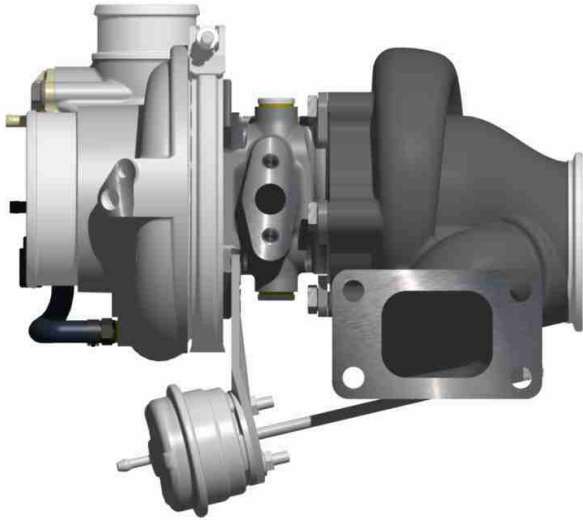

Turbo Frame Dimensions

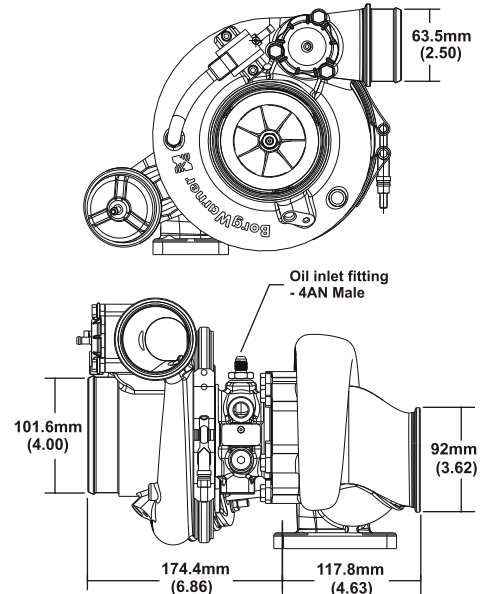

Turbo Features

- ✓ Gamma-Ti Turbine Wheel
- ✓ Dual Ball Bearing Assy with Metal Cage
- ✓ Forged Milled Extended Tip Compressor Wheel
- ✓ Stainless Steel Turbine Housing
- ✓ Water Cooled Bearing Housing
- ✓ Large Internal Wastegate (where applicable)
- ✓ Compressor Recirculation Valve (a.k.a BOV)
- ✓ Boost Control Solenoid Valve
- ✓ Standard T3 Mounting Flange

Not included with turbo assemblies:

- Speed sensor
- Turbine outlet V-Band
- Turbine inlet gasket
- Oil drain gasket or drain port fitting

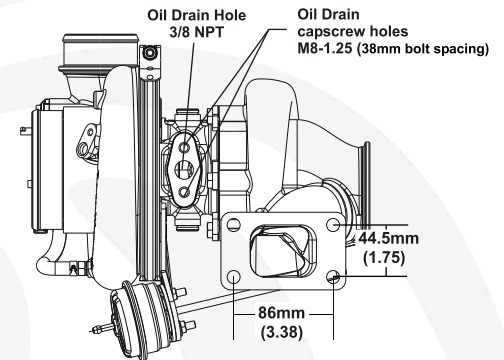

Compressor Map

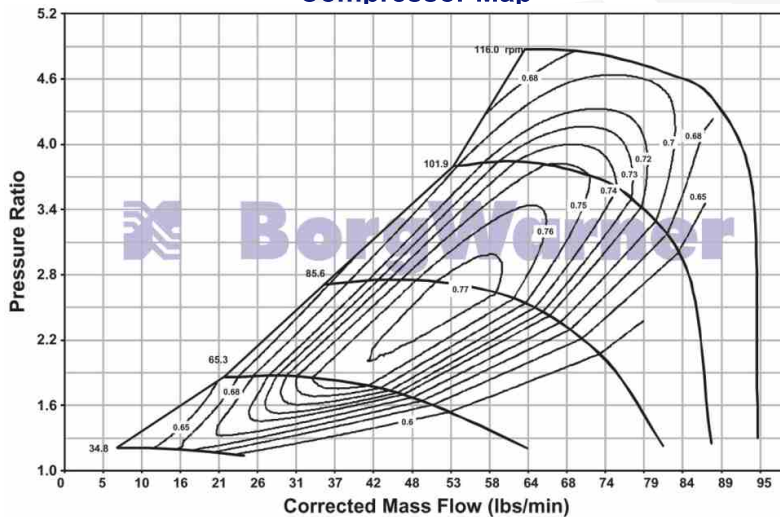

Super Core Configuration

The following parts are not included as part of the super-core assembly; turbine housing, assembly, clamp plate hardware, wastegate parts.

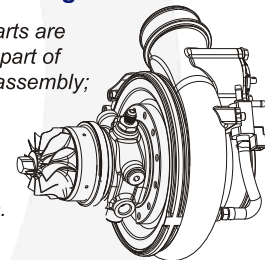

Turbine Housing Options

Turbine Housing Part Number	inlet flange A/R shape	Housing Config
12801008002	0.83 T3	Single Scroll WG
12801019001	1.05 T4	Twin Scroll Non-WG

Turbo Part Number	Turbo Frame Size	Super Core Part Number	Comp. Whl O.D. (in)	Comp. Whl Inducer Dia (in)	Comp. Whl O.D.(mm)	Comp. Whl Inducer Dia(mm)	Turb. Whl OD(mm)	Turb. A/R	Inlet Flange Config
179358	B2	179356	3.63	2.67	92.2	67.8	80.0	.83	T3