

GT1548

Garrett®
by Honeywell

2000	DISPLACEMENT 1.0L - 1.6L HORSEPOWER 100 - 200
1900	
1800	
1700	
1600	
1500	
1400	
1300	
1200	
1100	
1000	
900	
800	
700	
600	
500	
400	
300	
200	
100	
0	



- Journal bearing, oil & water-cooled CHRA
- Internally wastegated turbine housing, complete with actuator
- Excellent for motorcycles and other small displacement engines

FLANGE	INLET		OUTLET	
	Component	Page	Diagram	Page
Compressor	82	15	82	15
Turbine	83	01	85	03
Oil	84	11	84	15
Water	86	13	86	13

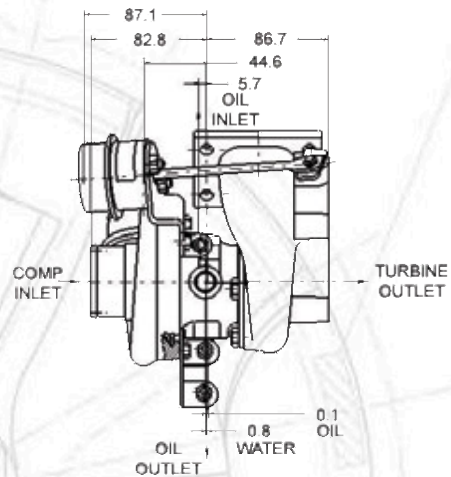

GT1548		COMPRESSOR				TURBINE		
Turbo PN	CHRA PN	Ind Whl Dia	Exd Whl Dia	Trim	A/R	Whl Dia	Trim	A/R
466755-3	431876-93	37.2mm	48.0mm	60	0.48	41.2mm	72	0.35

