

- Journal bearing, oil-cooled CHRA
- Internally wastegated turbine housing, complete with actuator
- Free float turbine housing (451503-1) option available
- Extremely efficient turbo

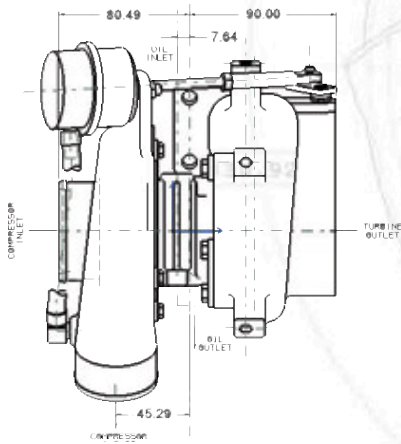

<b>DISPLACEMENT 1.7L - 2.5L</b>	<b>HORSEPOWER 150 - 260</b>	2000
		1900
		1800
		1700
		1600
		1500
		1400
		1300
		1200
		1100
		1000
		900
		800
		700
		600
		500
	400	
	300	
	200	
	100	
	0	

Component	INLET		OUTLET	
	Page	Diagram	Page	Diagram
Compressor	82	21	82	15
Turbine	83	01	85	10
Oil	See Note		84	16
Water	-	-	-	-

GT2252		COMPRESSOR				TURBINE		
Turbo PN	CHRA PN	Ind Whl Dia	Exd Whl Dia	Trim	A/R	Whl Dia	Trim	A/R
452187-6	451298-6	40.2mm	52.0mm	60	0.51	50.3mm	72	0.67

TURBINE HOUSING OPTIONS	
PN	A/R
451503-1	0.56

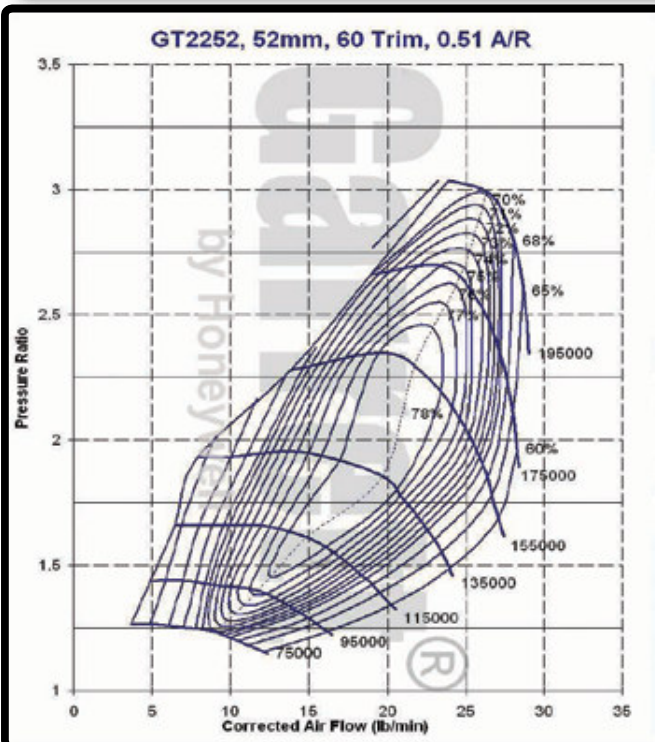

Dimension Note:  
Oil Inlet: Both PN - M10x1.0 (F) or M10x1.0 (M)

