

GT2259

Garrett®
by Honeywell

2000	DISPLACEMENT 1.7L - 2.5L
1900	
1800	
1700	
1600	
1500	
1400	
1300	
1200	
1100	
1000	
900	
800	
700	
600	
500	
400	
300	
200	
100	
0	

HORSEPOWER 160 - 280



- Journal bearing, oil-cooled CHRA
- Free floating, non-wastegated turbine housing
- Internally wastegated turbine housing available (PN 436313-6)
- Extremely efficient turbo

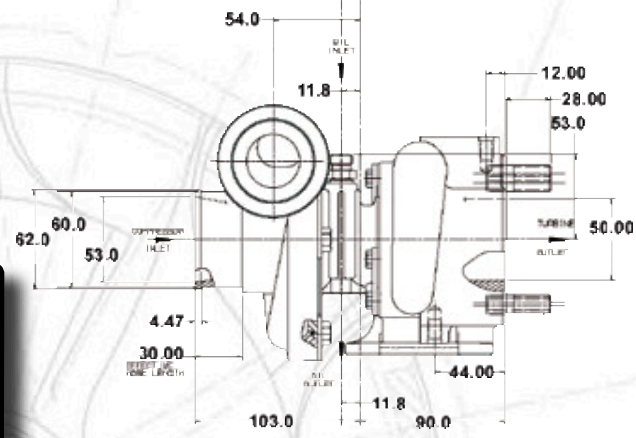

Component	INLET		OUTLET	
	Page	Diagram	Page	Diagram
Compressor	82	22	82	05
Turbine	83	01	85	06
Oil	See Note		84	16
Water	-	-	-	-

GT2259		COMPRESSOR				TURBINE		
Turbo PN	CHRA PN	Ind Whl Dia	Exd Whl Dia	Trim	A/R	Whl Dia	Trim	A/R
452214-3	451298-9	42.8mm	59.4mm	52	0.42	50.3mm	72	0.56

TURBINE HOUSING OPTIONS	
PN	A/R
436313-6	0.67

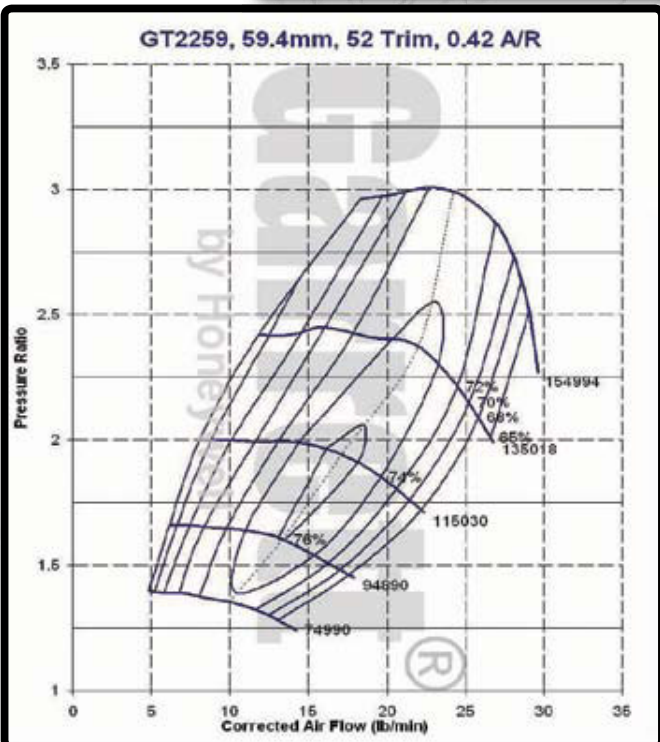

Dimension Note:
Oil Inlet: Both PN - M10x1.0 (F) or M14x1.0 (M)

