

- Dual ball bearing, oil & water-cooled CHRA
- Internally wastegated turbine housing, complete with actuator
- Smallest ball bearing turbocharger
- Great size for applications with packaging constraints

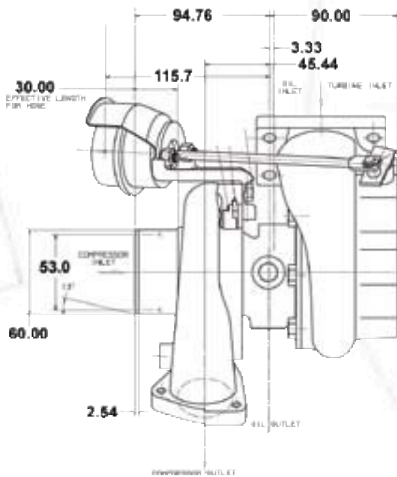

DISPLACEMENT 1.4L - 2.2L

HORSEPOWER 170 - 270

2000
1900
1800
1700
1600
1500
1400
1300
1200
1100
1000
900
800
700
600
500
400
300
200
100
0

Component	INLET		OUTLET	
	Page	Diagram	Page	Diagram
Compressor	82	22	82	04
Turbine	83	01	85	11
Oil	84	11	84	18
Water	86	13	86	13

GT2554R		COMPRESSOR				TURBINE		
Turbo PN	CHRA PN	Ind Whl Dia	Exd Whl Dia	Trim	A/R	Whl Dia	Trim	A/R
471171-3	446179-24	42.1mm	54.3mm	60	0.80	53.0mm	62	0.64

