

GT2560R

Garrett®
by Honeywell

2000	DISPLACEMENT 1.6L - 2.5L
1900	
1800	
1700	
1600	
1500	
1400	
1300	
1200	
1100	
1000	
900	
800	
700	
600	
500	
400	
300	
200	
100	
0	



- Dual ball bearing, oil & water-cooled CHRA
- Internally wastegated turbine housing complete with actuator
- Turbine housing is cast from high-nickel "Ni-Resist" material (466541-4 only)
- Turbine wheel is cast from "Inconel" material for extreme applications (466541-4 only)
- OEM turbocharger on Nissan SR20DET engine
- Upgrade for GT2554R (471171-3), outline interchangeable except compressor inlet

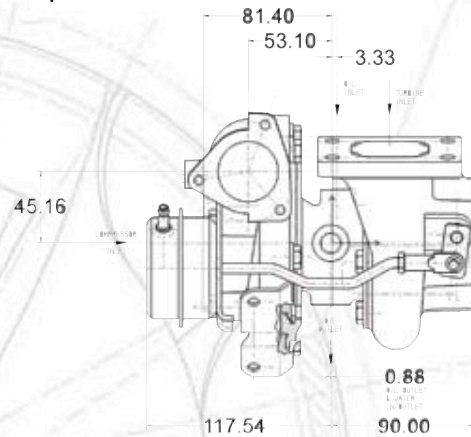

Component	INLET		OUTLET	
	Page	Diagram	Page	Diagram
Compressor	82	02	82	04
Turbine	83	01	85	11
Oil	84	11	84	18
Water	86	13	86	13

GT2560R		COMPRESSOR				TURBINE		
Turbo PN	CHRA PN	Ind Whl Dia	Exd Whl Dia	Trim	A/R	Whl Dia	Trim	A/R
466541-1	446179-12	46.5mm	60.1mm	60	0.60	53.0mm	62	0.64
466541-4	446179-38	46.5mm	60.1mm	60	0.60	53.0mm	62	0.64

