

- Dual ball bearing, oil & water-cooled CHRA
- Internally wastegated turbine housing, complete with actuator
- Turbine housing is cast from high-nickel "Ni-Resist" material
- Turbine wheel is cast from "Inconel" material for extreme applications
- Similar to GT2554R (471171-3) except for slightly larger turbine wheel, different turbine housing and wheel materials

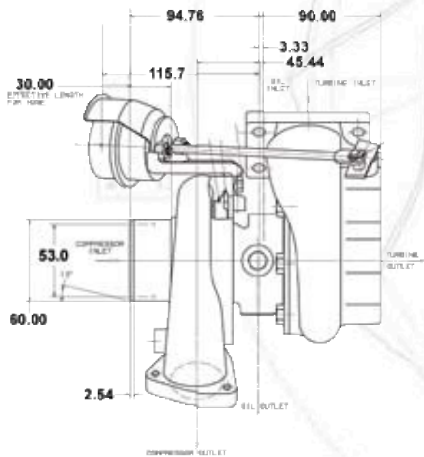

Component	INLET		OUTLET	
	Page	Diagram	Page	Diagram
Compressor	82	22	82	04
Turbine	83	01	85	11
Oil	84	11	84	18
Water	86	13	86	13

DISPLACEMENT 1.4L - 2.2L	HORSEPOWER 170 - 270	2000
		1900
		1800
		1700
		1600
		1500
		1400
		1300
		1200
		1100
		1000
		900
		800
		700
		600
		500
		400
	300	
	200	
	100	
	0	

GT2854R		COMPRESSOR				TURBINE		
Turbo PN	CHRA PN	Ind Whl Dia	Exd Whl Dia	Trim	A/R	Whl Dia	Trim	A/R
471171-9	446179-47	42.1mm	54.3mm	60	0.80	53.9mm	62	0.64

