

2000	DISPLACEMENT 1.8L - 3.0L
1900	
1800	
1700	
1600	
1500	
1400	
1300	
1200	
1100	
1000	
900	
800	
700	
600	
500	
400	
300	
200	
100	
0	

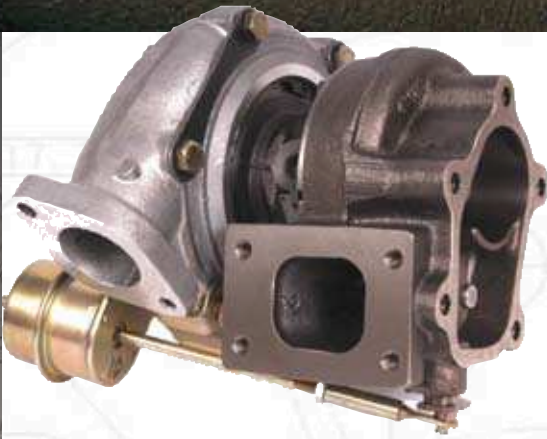

- Dual ball bearing, oil & water-cooled CHRA
- Internally wastegated turbine housing; 780371-1 complete with actuator, 707160-9 does NOT include actuator
- Turbine housing has a unique “compact” 5-bolt outlet that is not interchangeable with traditional T25 5-bolt outlets
- Turbine housing cast from high-nickel “Ni-Resist” material
- Turbine wheel is cast from “Inconel” material for extreme applications
- Bolt-on upgrade for Nissan RB26DETT

FLANGE	INLET		OUTLET	
	Component	Page	Diagram	Page
Compressor	82	02	82	01
Turbine	83	02	85	09
Oil	84	11	84	15
Water	86	13	86	13

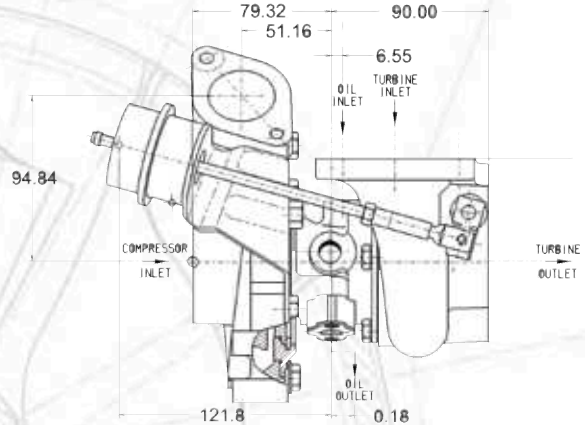

GT2859R		COMPRESSOR				TURBINE		
Turbo PN	CHRA PN	Ind Whl Dia	Exd Whl Dia	Trim	A/R	Whl Dia	Trim	A/R
780371-1	446179-65	44.5mm	59.4mm	56	0.42	53.9mm	62	0.64
707160-9	446179-65	44.5mm	59.4mm	56	0.42	53.9mm	62	0.64

TURBINE HOUSING OPTIONS	
PN	A/R
430609-230*	0.64
430609-231*	0.86

* Note: allows turbo to be outline interchangeable with other turbos using the traditional 5-bolt turbine housing (Diagram 85-11) Housing fits over turbine wheel but actuator/wastegate fitment may need to be adjusted

