

GT2860RS

The "Disco Potato"

Garrett®
by Honeywell

DISPLACEMENT 1.8L - 3.0L
HORSEPOWER 250 - 360



- Dual ball bearing, oil & water-cooled CHRA
- Internally wastegated turbine housing complete with actuator
- Upgrade turbocharger for GT2554R (471171-3) and GT2560R (466541-1); turbine housing flanges are outline interchangeable
- Turbine wheel is cast from "Inconel" material for extreme applications
- "Disco Potato" refers to the Nissan Sentra (potato-shaped body) with psychedelic color-change paint (disco) that was fitted with one of the first GT2860RS' in a project car build. The name stuck.

FLANGE	INLET		OUTLET	
Component	Page	Diagram	Page	Diagram
Compressor	82	28	82	19
Turbine	83	01	85	11
Oil	84	11	84	18
Water	86	13	86	13

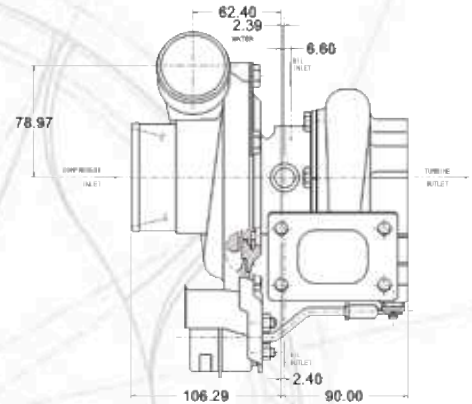

GT2860RS		COMPRESSOR				TURBINE		
Turbo PN	CHRA PN	Ind Whl Dia	Exd Whl Dia	Trim	A/R	Whl Dia	Trim	A/R
739548-1	446179-66	47.2mm	60.1mm	62	0.60	53.9mm	76	0.86
739548-5	446179-66	47.2mm	60.1mm	62	0.60	53.9mm	76	0.64

TURBINE HOUSING OPTIONS	
PN	A/R
430609-230	0.64
430609-231	0.86

