

- Dual ball bearing, oil & water-cooled CHRA
- Internally wastegated turbine housing, actuator NOT included
- Turbine wheel is cast from "Inconel" material for extreme applications

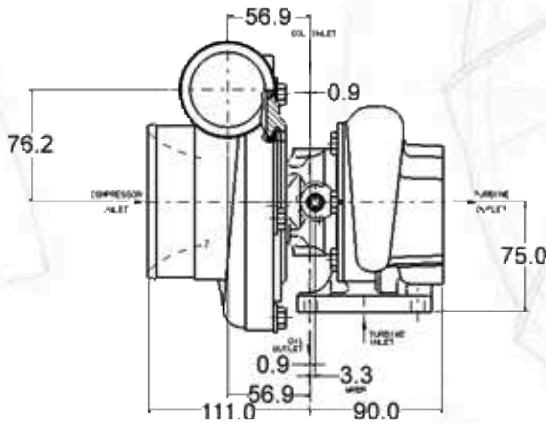

DISPLACEMENT 1.8L - 3.0L	HORSEPOWER 280 - 480	2000
		1900
		1800
		1700
		1600
		1500
		1400
		1300
		1200
		1100
		1000
		900
		800
		700
		600
		500
		400
	300	
	200	
	100	
	0	

Component	INLET		OUTLET	
	Page	Diagram	Page	Diagram
Compressor	82	35	82	24
Turbine	83	01	85	11
Oil	84	11	84	18
Water	86	13	86	13

GT2876R		COMPRESSOR				TURBINE		
Turbo PN	CHRA PN	Ind Whl Dia	Exd Whl Dia	Trim	A/R	Whl Dia	Trim	A/R
705330-1	446179-18	52.8mm	76.1mm	48	0.70	53.9mm	76	0.64
705330-2	446179-18	52.8mm	76.1mm	48	0.70	53.9mm	76	0.86

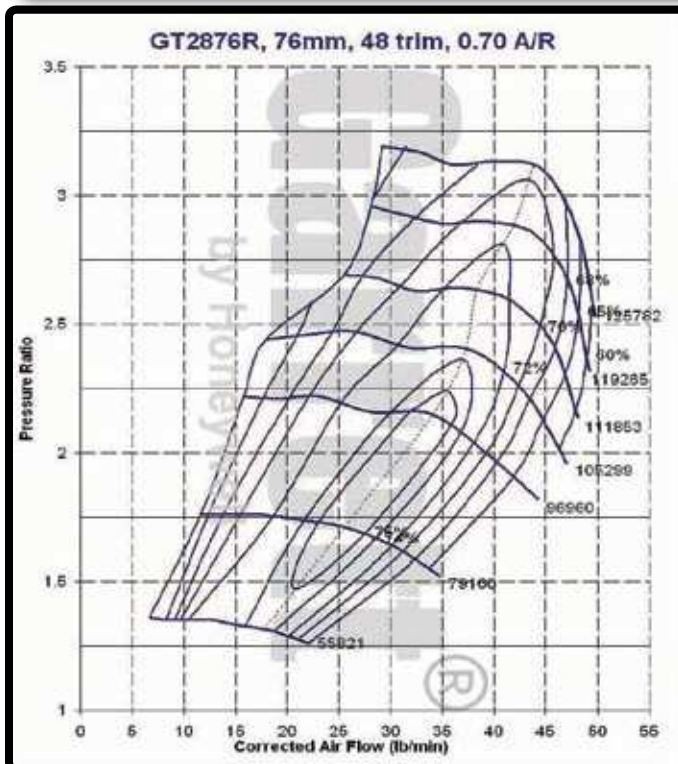

TURBINE HOUSING OPTIONS	
PN	A/R
430609-230	0.64
430609-231	0.86

