

- Journal bearing, oil-cooled CHRA
- Internally wastegated turbine housing complete with actuator
- Wastegated and free float turbine housing options available

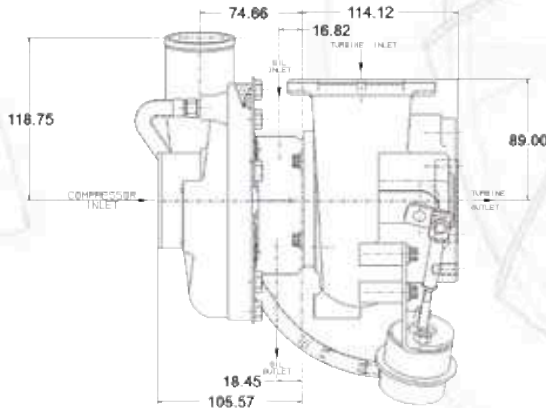

DISPLACEMENT 2.0L - 3.0L	HORSEPOWER 200 - 420	2000
		1900
		1800
		1700
		1600
		1500
		1400
		1300
		1200
		1100
		1000
		900
		800
		700
		600
		500
	400	
	300	
	200	
	100	
	0	

Component	INLET		OUTLET	
	Page	Diagram	Page	Diagram
Compressor	82	27	82	17
Turbine	84	01	86	01
Oil	84	13	84	08
Water	-	-	-	-

GT3271R		COMPRESSOR				TURBINE		
Turbo PN	CHRA PN	Ind Whl Dia	Exd Whl Dia	Trim	A/R	Whl Dia	Trim	A/R
452203-1	436058-3	51.2mm	71.0mm	52	0.50	64.0mm	73	0.78

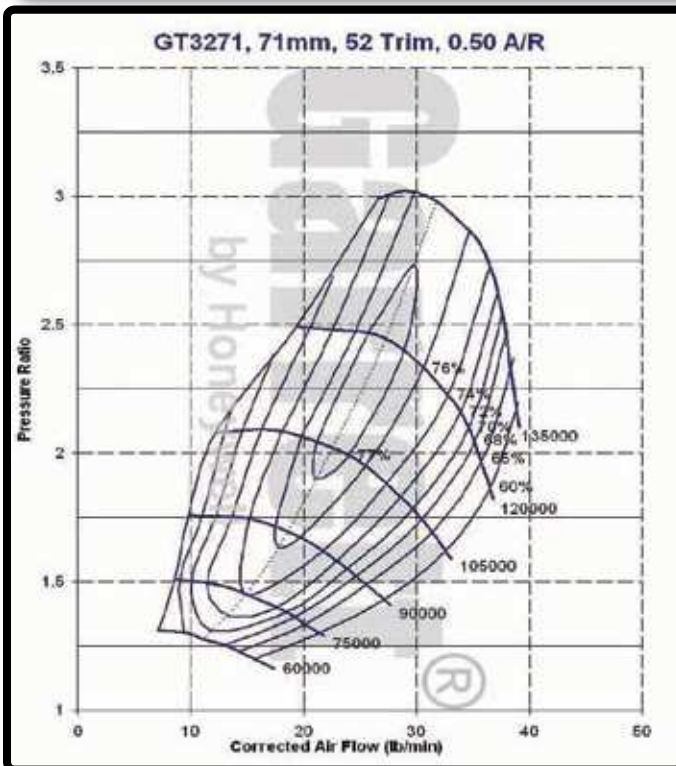

TURBINE HOUSING OPTIONS	
PN	A/R
451225-26*	0.78
435066-32+	0.69

* Note: Free float turbine housing option
+Note: Wastegated turbine housing option

