

2000	DISPLACEMENT 2.0L - 4.5L
1900	
1800	
1700	
1600	
1500	
1400	
1300	
1200	
1100	
1000	
900	
800	
700	
600	
500	
400	
300	
200	
100	
0	

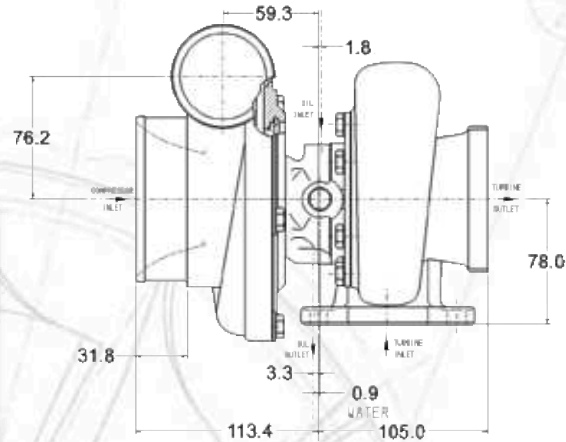

- Dual ball bearing, oil & water-cooled CHRA
- Turbine housing is cast from high-nickel "Ni-Resist" material for extreme applications
- Turbine wheel is cast from "inconel" material for extreme applications
- Works well in twin-turbo applications for large V8 engines

FLANGE	INLET		OUTLET	
	Component	Page	Diagram	Page
Compressor	82	33	82	24
Turbine	83	04	85	07
Oil	84	11	84	18
Water	86	13	86	13



GT3582R		COMPRESSOR				TURBINE		
Turbo PN	CHRA PN	Ind Whl Dia	Exd Whl Dia	Trim	A/R	Whl Dia	Trim	A/R
714568-1	706451-5	61.4mm	82.0mm	56	0.70	68.0mm	84	1.06
714568-2	706451-5	61.4mm	82.0mm	56	0.70	68.0mm	84	0.82
714568-3	706451-5	61.4mm	82.0mm	56	0.70	68.0mm	84	0.63

TURBINE HOUSING OPTIONS			
PN	A/R	Inlet	Outlet
740902-10 ⁺	1.06	T3	V Band
740902-11 ⁺	0.82	T3	V Band
740902-12 ⁺	0.63	T3	V Band
740902-16 [^]	1.06	T4	V Band
740902-17 [^]	0.82	T4	V Band
740902-18 [^]	0.63	T4	V Band

Dimension Note: Turbine Housing Options

⁺ Note: Inlet flange: 83-04; Outlet flange: 86-13

[^] Note: Inlet flange: 83-10; Outlet flange: 86-13

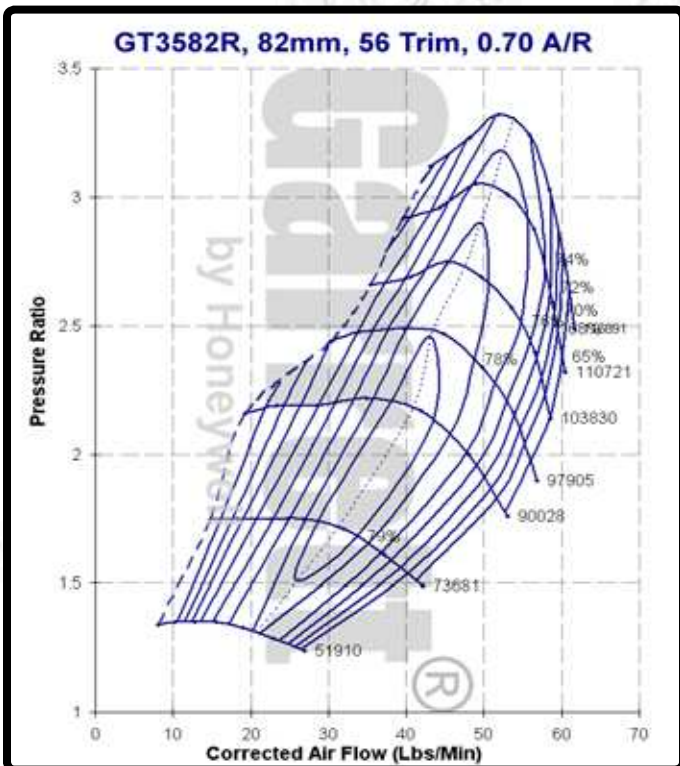

- Dual ball bearing, oil & water-cooled CHRA
- Ported shroud compressor housing to increase surge resistance
- Turbine housing is cast from high-nickel “Ni-Resist” material for extreme applications
- Turbine wheel is cast from “inconel” material for extreme applications
- Works well in twin-turbo applications for large V8 engines

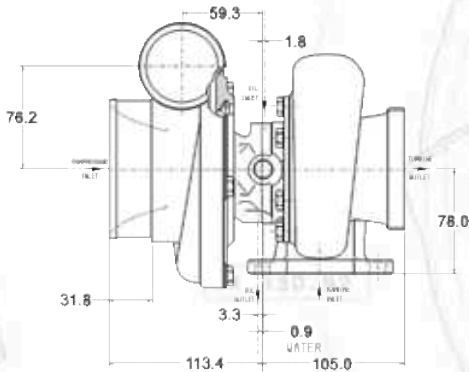

Component	INLET		OUTLET	
	Page	Diagram	Page	Diagram
Compressor	82	33	82	24
Turbine	83	04	86	13
Oil	84	11	84	18
Water	86	13	86	13

DISPLACEMENT 2.0L - 4.5L	HORSEPOWER 400 - 675	2000
		1900
		1800
		1700
		1600
		1500
		1400
		1300
		1200
		1100
		1000
		900
		800
		700
		600
		500
		400
300		
200		
100		
0		

GT3582R		COMPRESSOR				TURBINE		
Turbo PN	CHRA PN	Ind Whl Dia	Exd Whl Dia	Trim	A/R	Whl Dia	Trim	A/R
714568-7	706451-5	61.4mm	82.0mm	56	0.70	68.0mm	84	1.06
714568-8	706451-5	61.4mm	82.0mm	56	0.70	68.0mm	84	0.82
714568-9	706451-5	61.4mm	82.0mm	56	0.70	68.0mm	84	0.63

TURBINE HOUSING OPTIONS			
PN	A/R	Inlet	Outlet
740902-4*	1.06	T3	4 Bolt
740902-5*	0.82	T3	4 Bolt
740902-6*	0.63	T3	4 Bolt
740902-16^	1.06	T4	V Band
740902-17^	0.82	T4	V Band
740902-18^	0.63	T4	V Band

Dimension Note: Turbine Housing Options
 * Note: Inlet flange: 83-04; Outlet flange: 85-07
 ^ Note: Inlet flange: 83-10; Outlet flange: 86-13

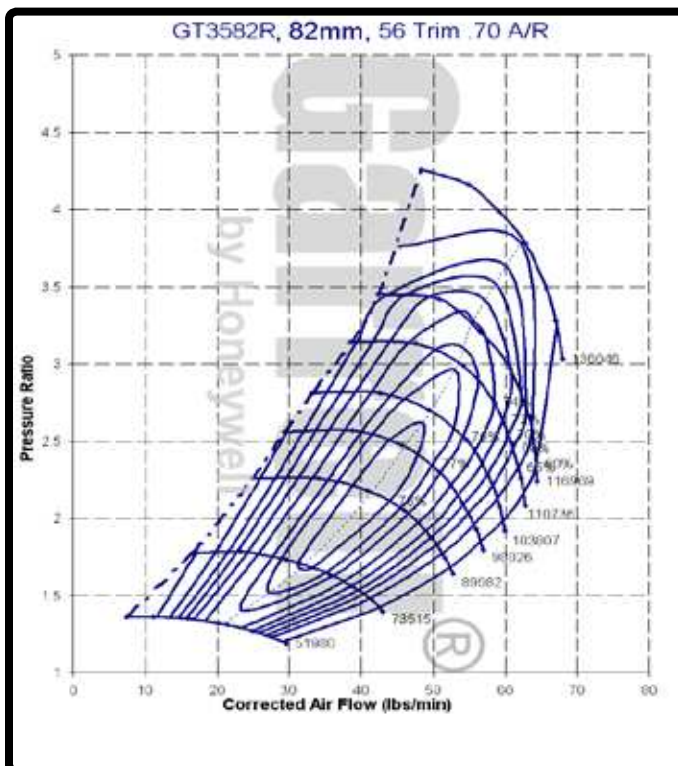

DISPLACEMENT 2.0L - 4.5L
HORSEPOWER 400 - 675

2000
1900
1800
1700
1600
1500
1400
1300
1200
1100
1000
900
800
700
600
500
400
300
200
100
0



- Dual ball bearing, oil & water-cooled CHRA
- Ported shroud compressor housing to increase surge resistance
- Turbine wheel is cast from "inconel" material for extreme applications
- Works well in twin-turbo applications for large V8 engines

FLANGE	INLET		OUTLET		
	Component	Page	Diagram	Page	Diagram
Compressor	82	33	82	24	
Turbine	83	10	86	13	
Oil	84	11	84	18	
Water	86	13	86	13	

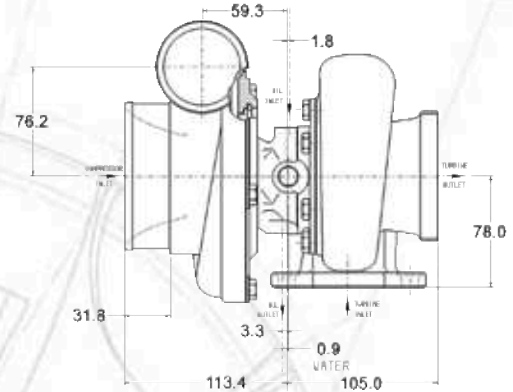

GT3582R		COMPRESSOR				TURBINE		
Turbo PN	CHRA PN	Ind Whl Dia	Exd Whl Dia	Trim	A/R	Whl Dia	Trim	A/R
714568-10	706451-5	61.4mm	82.0mm	56	0.70	68.0mm	84	1.06
714568-11	706451-5	61.4mm	82.0mm	56	0.70	68.0mm	84	0.82
714568-12	706451-5	61.4mm	82.0mm	56	0.70	68.0mm	84	0.63

TURBINE HOUSING OPTIONS

PN	A/R	Inlet	Outlet
740902-4*	1.06	T3	4 Bolt
740902-5*	0.82	T3	4 Bolt
740902-6*	0.63	T3	4 Bolt
740902-16†	1.06	T3	V Band
740902-17†	0.82	T3	V Band
740902-18†	0.63	T3	V Band

Dimension Note: Turbine Housing Options

* Note: Inlet flange: 83-04; Outlet flange: 85-07

† Note: Inlet flange: 83-04; Outlet flange: 86-13

