

2000	DISPLACEMENT 2.0L - 4.0L HORSEPOWER 320 - 500
1900	
1800	
1700	
1600	
1500	
1400	
1300	
1200	
1100	
1000	
900	
800	
700	
600	
500	
400	
300	
200	
100	
0	

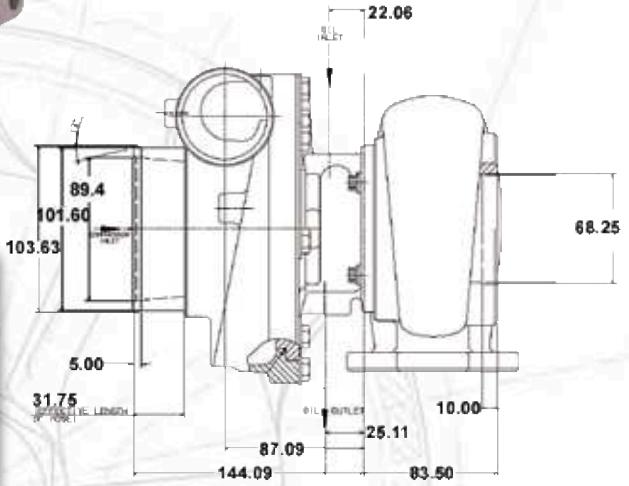

- Journal bearing, oil-cooled CHRA
- Free float, non-wastegated turbine housing
- Extremely efficient turbo

FLANGE	INLET		OUTLET	
Component	Page	Diagram	Page	Diagram
Compressor	82	33	82	22
Turbine	84	01	85	04
Oil	84	19	84	08
Water	-	-	-	-



GT3776		COMPRESSOR				TURBINE		
Turbo PN	CHRA PN	Ind Whl Dia	Exd Whl Dia	Trim	A/R	Whl Dia	Trim	A/R
452159-1	436085-1	55.0mm	76.2mm	52	0.54	72.5mm	84	1.12

