

- Journal bearing, oil-cooled CHRA
- Free float, non-wastegated turbine housing

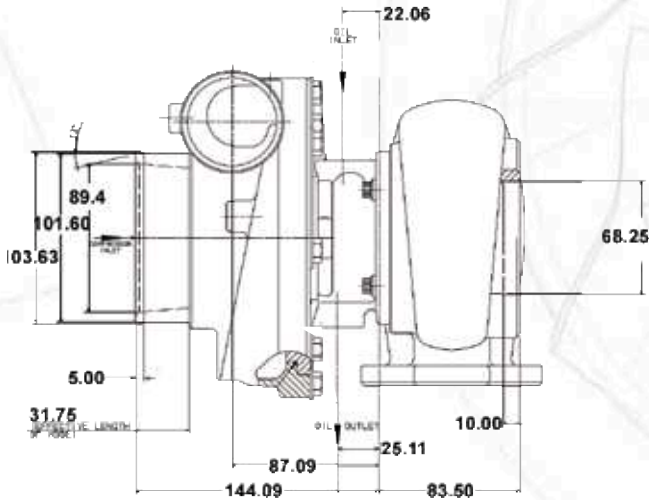

DISPLACEMENT 2.0L - 4.0L	HORSEPOWER 350 - 550	2000
		1900
		1800
		1700
		1600
		1500
		1400
		1300
		1200
		1100
		1000
		900
		800
		700
		600
		500
	400	
	300	
	200	
	100	
	0	



Component	INLET		OUTLET	
	Page	Diagram	Page	Diagram
Compressor	82	33	82	22
Turbine	84	01	85	04
Oil	84	19	84	08
Water	-	-	-	-

GT3782		COMPRESSOR				TURBINE		
Turbo PN	CHRA PN	Ind Whl Dia	Exd Whl Dia	Trim	A/R	Whl Dia	Trim	A/R
452159-3	436085-5	59.1mm	82.0mm	52	0.54	72.5mm	84	1.12

