

2000	DISPLACEMENT 2.0L - 5.0L
1900	
1800	
1700	
1600	
1500	
1400	
1300	
1200	
1100	
1000	
900	
800	
700	
600	
500	
400	
300	
200	
100	
0	

HORSEPOWER 400 - 675

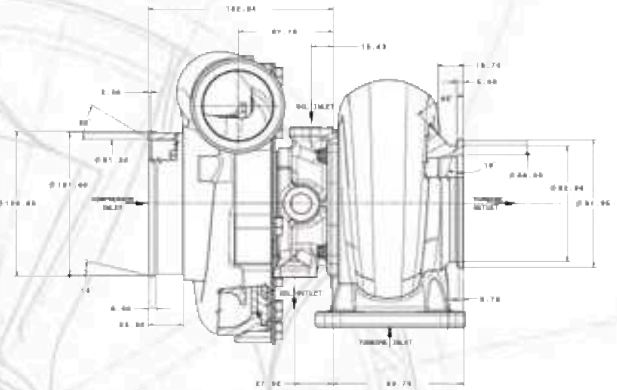

- Dual ball bearing, oil & water-cooled CHRA
- Free float, non-wastegated turbine housing
- Ported shroud compressor housing to increase surge resistance



FLANGE	INLET		OUTLET	
	Component	Page	Diagram	Page
Compressor	82	31	82	25
Turbine	84	03	86	04
Oil	84	13	84	08
Water	86	14	86	14

GT3788R		COMPRESSOR				TURBINE		
Turbo PN	CHRA PN	Ind Whl Dia	Exd Whl Dia	Trim	A/R	Whl Dia	Trim	A/R
772719-1	751451-12	63.5mm	88.0mm	52	0.72	72.5mm	78	0.89
772719-2	751451-12	63.5mm	88.0mm	52	0.72	72.5mm	78	0.99
772719-3	751451-12	63.5mm	88.0mm	52	0.72	72.5mm	78	1.11

