

2000	DISPLACEMENT 2.0L - 6.0L HORSEPOWER 400 - 725
1900	
1800	
1700	
1600	
1500	
1400	
1300	
1200	
1100	
1000	
900	
800	
700	
600	
500	
400	
300	
200	
100	
0	

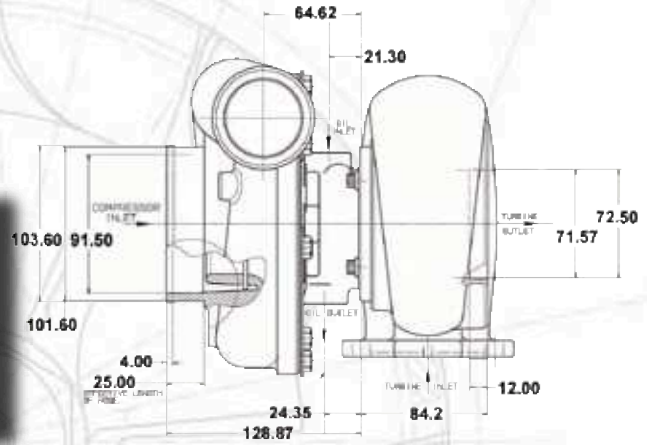

- Journal bearing, oil-cooled CHRA
- Free float, non-wastegated turbine housing
- Ported shroud compressor housing to increase surge resistance

Component	FLANGE		INLET		OUTLET	
	Page	Diagram	Page	Diagram	Page	Diagram
Compressor	82	31	82	25		
Turbine	84	04	86	03		
Oil	84	13	84	08		
Water	-	-	-	-		



GT4088		COMPRESSOR				TURBINE		
Turbo PN	CHRA PN	Ind Whl Dia	Exd Whl Dia	Trim	A/R	Whl Dia	Trim	A/R
703457-2	449739-34	64.7mm	88.0mm	54	0.72	77.6mm	83	1.34

TURBINE HOUSING OPTIONS	
PN	A/R
434309-88	1.19

