

2000	DISPLACEMENT 2.0L - 7.0L
1900	
1800	
1700	
1600	
1500	
1400	
1300	
1200	
1100	
1000	
900	
800	
700	
600	
500	
400	
300	
200	
100	
0	

HORSEPOWER 450 - 1000



- Dual ball bearing, oil & water-cooled CHRA
- Free float, non-wastegated turbine housing
- Ported shroud compressor housing to reduce the occurrence of surge
- Outline interchangeable with the GTX4202R and the journal bearing GT4202 (with the exception of water cooling)

FLANGE	INLET		OUTLET	
	Component	Page	Diagram	Page
Compressor	82	37	82	07
Turbine	84	03	86	06
Oil	84	17	84	08
Water	86	14	86	14

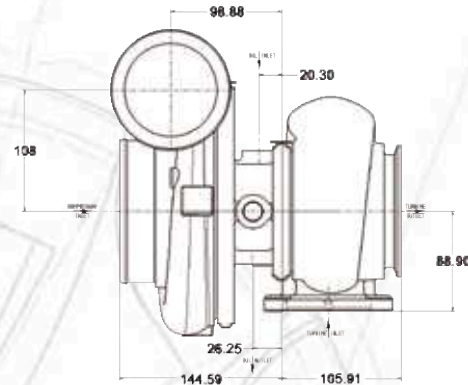

GT4202R		COMPRESSOR				TURBINE		
Turbo PN	CHRA PN	Ind Whl Dia	Exd Whl Dia	Trim	A/R	Whl Dia	Trim	A/R
774595-5	451888-11	74.7mm	102.3mm	53	0.60	82.0mm	84	1.01
774595-6	451888-11	74.7mm	102.3mm	53	0.60	82.0mm	84	1.15
774595-7	451888-11	74.7mm	102.3mm	53	0.60	82.0mm	84	1.28
774595-8	451888-11	74.7mm	102.3mm	53	0.60	82.0mm	84	1.44

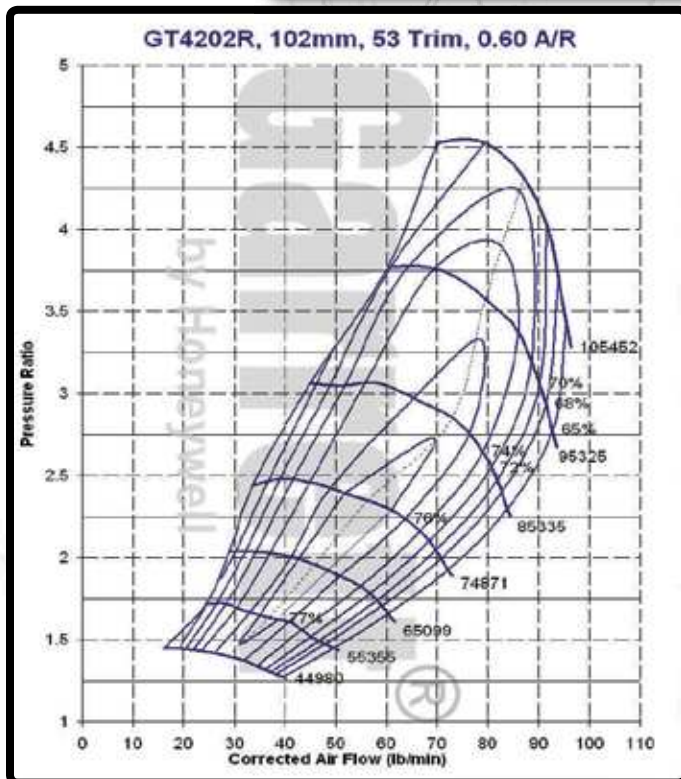

TURBINE HOUSING OPTIONS	
PN	A/R
757707-10*	1.01
757707-9*	1.15

\*Note: inlet flange: Page - 84 Diagram - 05

