

2000	DISPLACEMENT 2.0L - 8.0L
1900	
1800	
1700	
1600	
1500	
1400	
1300	
1200	
1100	
1000	
900	
800	
700	
600	
500	
400	
300	
200	
100	
0	

HORSEPOWER 600 - 1100



- Dual ball bearing, oil & water-cooled CHRA
- Free float, non-wastegated turbine housing
- Optional turbine housings with T4 or diesel turbine inlet flange
- Ported shroud compressor housing to increase surge resistance

Component	INLET		OUTLET	
	Page	Diagram	Page	Diagram
Compressor	82	38	82	30
Turbine	84	03	86	06
Oil	84	17	84	08
Water	86	14	86	14

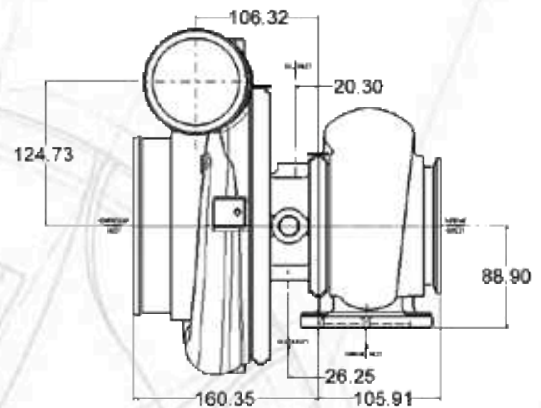

GT4508R		COMPRESSOR				TURBINE		
Turbo PN	CHRA PN	Ind Whl Dia	Exd Whl Dia	Trim	A/R	Whl Dia	Trim	A/R
774596-1	451888-28	79.8mm	108.0mm	55	0.69	87.0mm	85	1.01
774596-2	451888-28	79.8mm	108.0mm	55	0.69	87.0mm	85	1.15
774596-3	451888-28	79.8mm	108.0mm	55	0.69	87.0mm	85	1.28
774596-4	451888-28	79.8mm	108.0mm	55	0.69	87.0mm	85	1.44

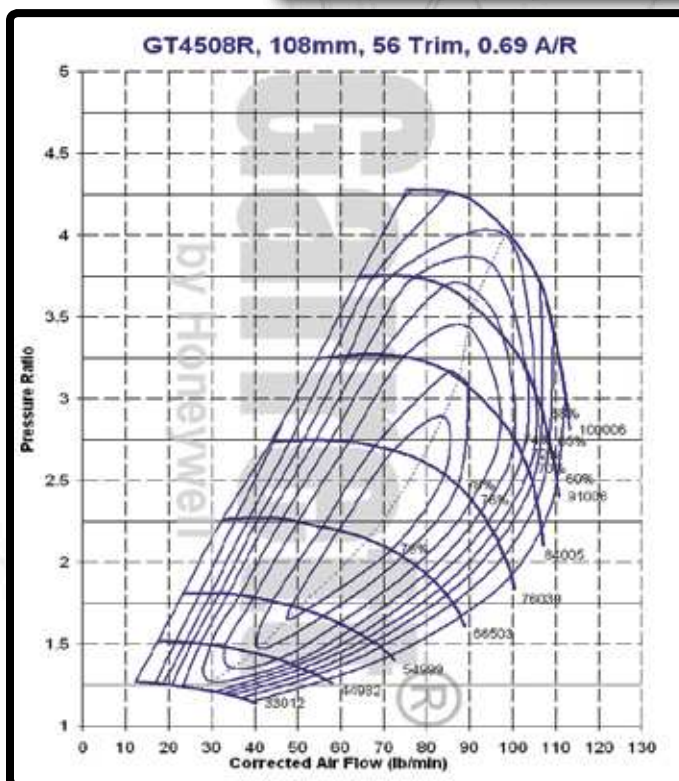

TURBINE HOUSING OPTIONS	
PN	A/R
757707-5	1.01
757707-6	1.15
757707-7	1.28
757707-8	1.44

