

2000	DISPLACEMENT 2.5L - 10.0L
1900	
1800	
1700	
1600	
1500	
1400	
1300	
1200	
1100	
1000	
900	
800	
700	
600	
500	
400	
300	
200	
100	
0	

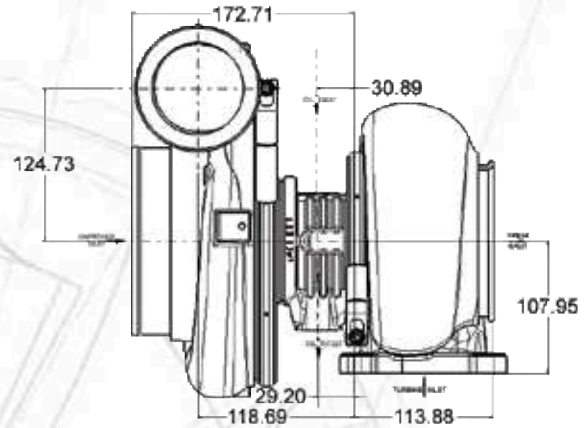

- Journal bearing, oil-cooled CHRA
- Free float, non-wastegated turbine housing
- Ported shroud compressor housing to increase surge resistance
- Outline interchangeable with the ball bearing GT4708R



FLANGE	INLET		OUTLET		
	Component	Page	Diagram	Page	Diagram
Compressor	82	38	82	30	
Turbine	83	05	86	10	
Oil	84	14	84	09	
Water	-	-	-	-	

GT4708		COMPRESSOR				TURBINE		
Turbo PN	CHRA PN	Ind Whl Dia	Exd Whl Dia	Trim	A/R	Whl Dia	Trim	A/R
763740-3	767564-1	79.8mm	108.0mm	55	0.69	92.7mm	82	0.96
763740-4	767564-1	79.8mm	108.0mm	55	0.69	92.7mm	82	1.08
763740-5	767564-1	79.8mm	108.0mm	55	0.69	92.7mm	82	1.23
763740-6	767564-1	79.8mm	108.0mm	55	0.69	92.7mm	82	1.39

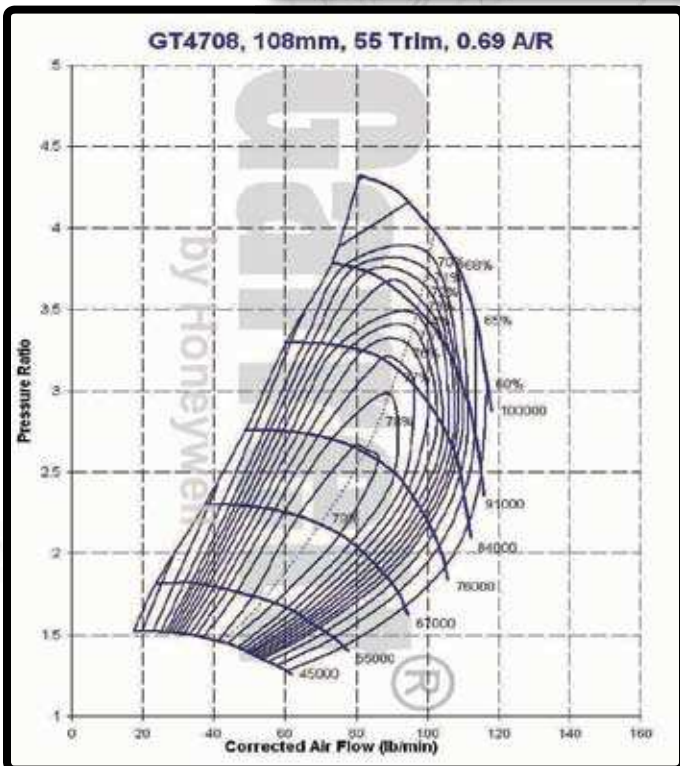

TURBINE HOUSING OPTIONS	
PN	A/R
761208-9	0.96
761208-10	1.08
761208-11	1.23
761208-12	1.39

