

- Dual ball bearing, oil-cooled CHRA
- Free float, non-wastegated turbine housing
- Ported shroud compressor housing to increase surge resistance
- Outline interchangeable with the journal bearing GT4708

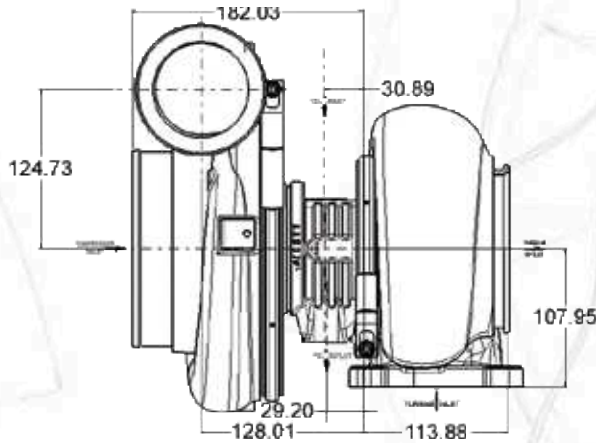

Component	INLET		OUTLET	
	Page	Diagram	Page	Diagram
Compressor	82	38	82	30
Turbine	83	05	86	10
Oil	84	12	84	08
Water	-	-	-	-

DISPLACEMENT 2.5L - 10.0L
HORSEPOWER 700 - 1150

2000
1900
1800
1700
1600
1500
1400
1300
1200
1100
1000
900
800
700
600
500
400
300
200
100
0

GT4708R		COMPRESSOR				TURBINE		
Turbo PN	CHRA PN	Ind Whl Dia	Exd Whl Dia	Trim	A/R	Whl Dia	Trim	A/R
769112-1	769210-1	79.8mm	108.0mm	55	0.69	92.7mm	82	0.96
769112-2	769210-1	79.8mm	108.0mm	55	0.69	92.7mm	82	1.08
769112-3	769210-1	79.8mm	108.0mm	55	0.69	92.7mm	82	1.23
769112-4	769210-1	79.8mm	108.0mm	55	0.69	92.7mm	82	1.39

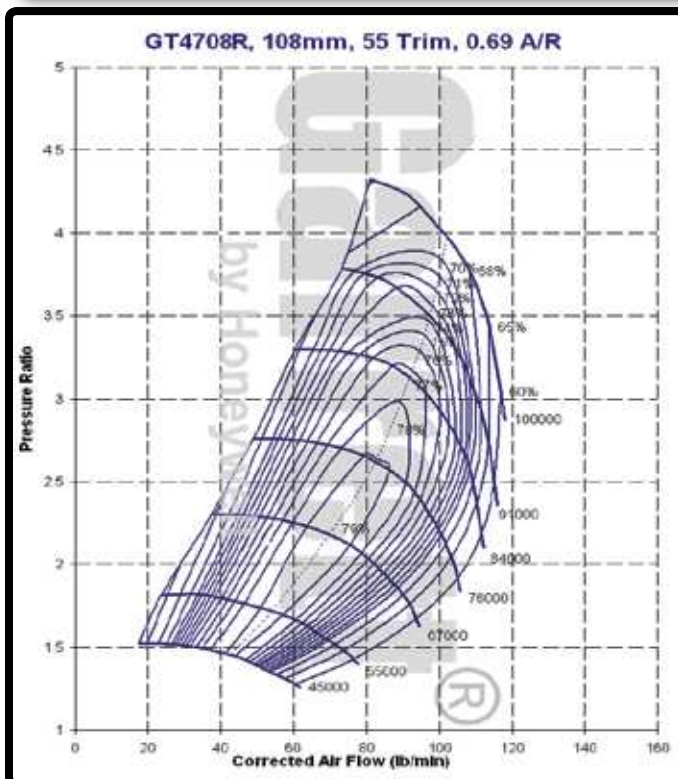

TURBINE HOUSING OPTIONS	
PN	A/R
761208-9	0.96
761208-10	1.08
761208-11	1.23
761208-12	1.39

