

2000	HORSEPOWER 800 - 1350	DISPLACEMENT 2.5L - 10.0L
1900		
1800		
1700		
1600		
1500		
1400		
1300		
1200		
1100		
1000		
900		
800		
700		
600		
500		
400		
300		
200		
100		
0		

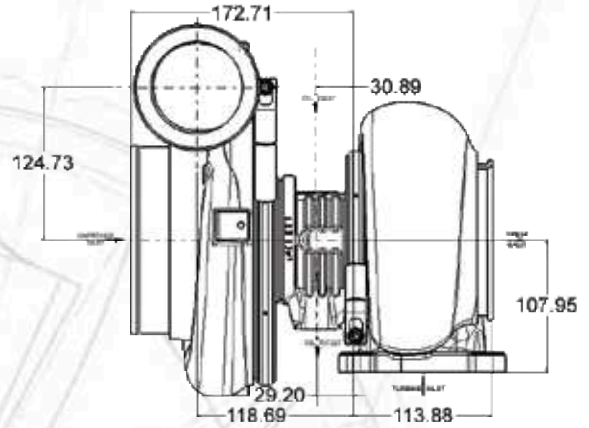

- Journal bearing, oil-cooled CHRA
- Free float, non-wastegated turbine housing
- Ported shroud compressor housing to increase surge resistance
- Outline interchangeable with the ball bearing GT4718R

Component	INLET		OUTLET	
	Page	Diagram	Page	Diagram
Compressor	82	38	82	30
Turbine	83	05	86	10
Oil	84	14	84	09
Water	-	-	-	-



GT4718		COMPRESSOR				TURBINE		
Turbo PN	CHRA PN	Ind Whl Dia	Exd Whl Dia	Trim	A/R	Whl Dia	Trim	A/R
763740-7	767564-2	87.8mm	117.6mm	56	0.69	92.7mm	82	0.96
763740-8	767564-2	87.8mm	117.6mm	56	0.69	92.7mm	82	1.08
763740-9	767564-2	87.8mm	117.6mm	56	0.69	92.7mm	82	1.23
763740-10	767564-2	87.8mm	117.6mm	56	0.69	92.7mm	82	1.39

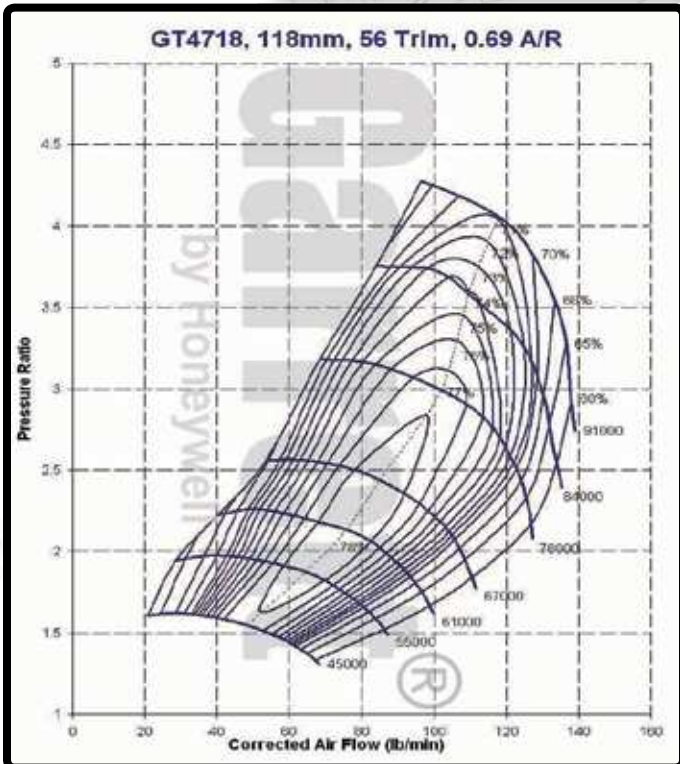

TURBINE HOUSING OPTIONS	
PN	A/R
761208-9	0.96
761208-10	1.08
761208-11	1.23
761208-12	1.39

