

2000	DISPLACEMENT 3.0L - 12.0L HORSEPOWER 850 - 1550
1900	
1800	
1700	
1600	
1500	
1400	
1300	
1200	
1100	
1000	
900	
800	
700	
600	
500	
400	
300	
200	
100	
0	

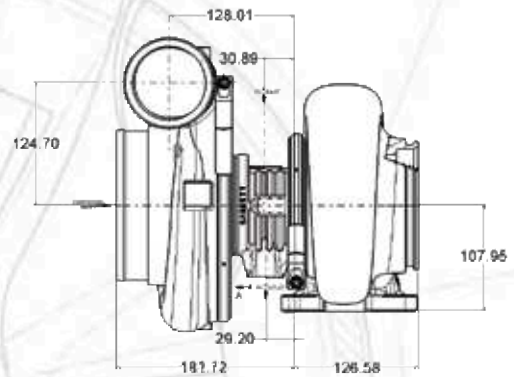

- Dual ball bearing, oil-cooled CHRA
- Free float, non-wastegated turbine housing
- Ported shroud compressor housing to increase surge resistance

FLANGE	INLET		OUTLET	
Component	Page	Diagram	Page	Diagram
Compressor	82	38	82	30
Turbine	83	05	86	10
Oil	84	20	84	21
Water	-	-	-	-



GT5533R		COMPRESSOR				TURBINE		
Turbo PN	CHRA PN	Ind Whl Dia	Exd Whl Dia	Trim	A/R	Whl Dia	Trim	A/R
769115-2	769210-3	91.2mm	133.3mm	47	0.69	111.5mm	84	1.00

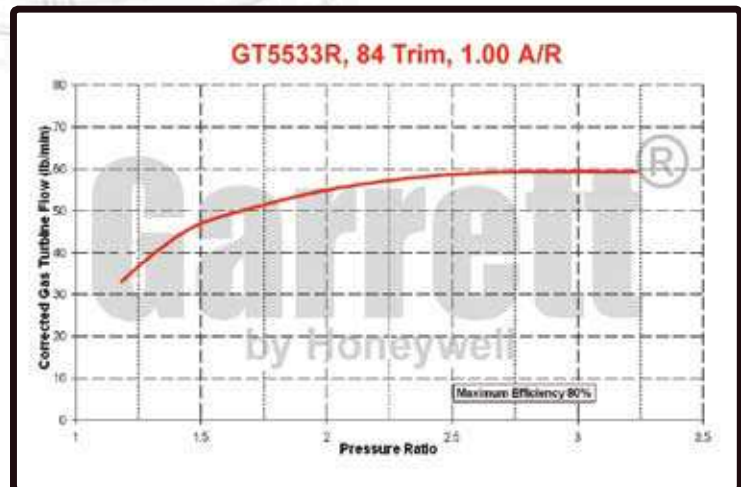
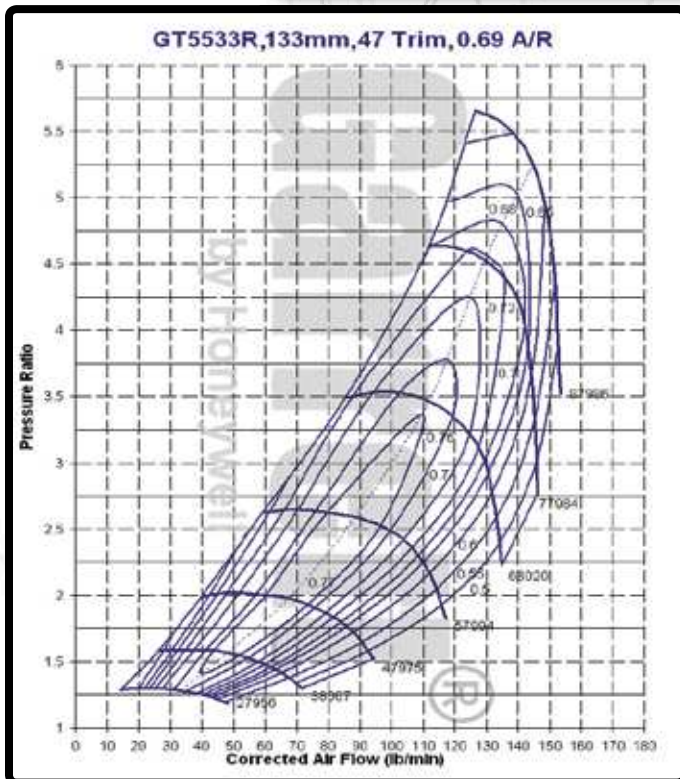

- Dual ball bearing, oil-cooled CHRA
- Free float, non-wastegated turbine housing
- Ported shroud compressor housing to increase surge resistance

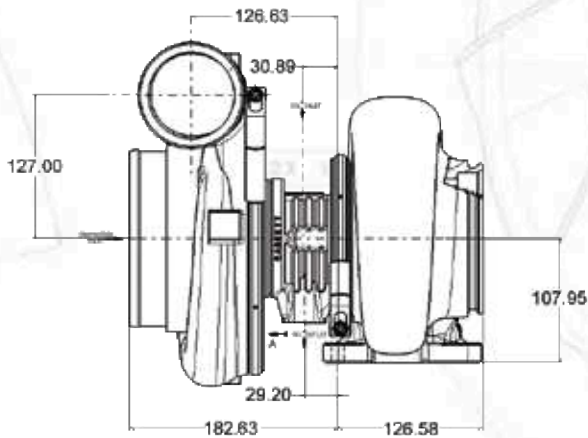

FLANGE	INLET		OUTLET		
	Component	Page	Diagram	Page	Diagram
Compressor	82	38	82	30	
Turbine	83	05	86	10	
Oil	84	20	84	21	
Water	-	-	-	-	

DISPLACEMENT 3.0L - 12.0L

HORSEPOWER 1100 - 1700

2000
1900
1800
1700
1600
1500
1400
1300
1200
1100
1000
900
800
700
600
500
400
300
200
100
0

GT5533R		COMPRESSOR				TURBINE		
Turbo PN	CHRA PN	Ind Whl Dia	Exd Whl Dia	Trim	A/R	Whl Dia	Trim	A/R
769115-7	769210-5	93.8mm	133.3mm	49.5	0.81	111.5mm	84	1.00

