

2000	DISPLACEMENT 3.0L - 12.0L
1900	
1800	
1700	
1600	
1500	
1400	
1300	
1200	
1100	
1000	
900	
800	
700	
600	
500	
400	
300	
200	
100	
0	

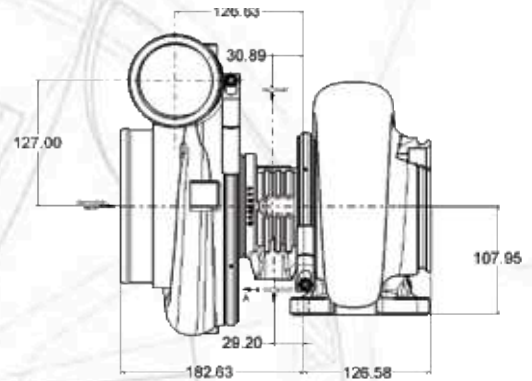

- Dual ball bearing, oil-cooled CHRA
- Free float, non-wastegated turbine housing
- Turbine wheel cast from “Inconel” material for extreme applications
- Largest Garrett® ball bearing turbo available
- Compressor wheel is machined from billet aluminum
- Ported shroud compressor housing to increase surge resistance

Component	INLET		OUTLET	
	Page	Diagram	Page	Diagram
Compressor	82	40	82	30
Turbine	83	05	86	10
Oil	84	20	84	21
Water	-	-	-	-



GT5541R		COMPRESSOR				TURBINE		
Turbo PN	CHRA PN	Ind Whl Dia	Exd Whl Dia	Trim	A/R	Whl Dia	Trim	A/R
777210-12	769210-7	105.8mm	141.0mm	56	0.81	111.5mm	84	1.00

