

- Journal bearing, oil-cooled CHRA
- Free float, non-wastegated turbine housing
- Largest Garrett® turbocharger available

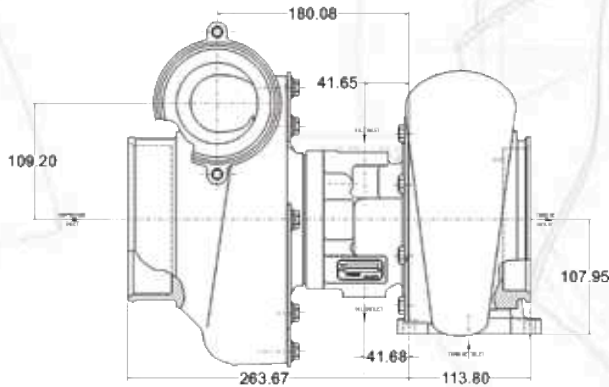

| Component | INLET | | OUTLET | |
|------------|-------|---------|--------|---------|
| | Page | Diagram | Page | Diagram |
| Compressor | 82 | 40 | 82 | 03 |
| Turbine | 83 | 05 | 86 | 09 |
| Oil | 84 | 14 | 84 | 09 |
| Water | - | - | - | - |

| | | |
|----------------------------------|-------------------------------|------|
| DISPLACEMENT 6.0L - 12.0L | HORSEPOWER 1350 - 2000 | 2000 |
| | | 1900 |
| | | 1800 |
| | | 1700 |
| | | 1600 |
| | | 1500 |
| | | 1400 |
| | | 1300 |
| | | 1200 |
| | | 1100 |
| | | 1000 |
| | | 900 |
| | | 800 |
| | | 700 |
| | | 600 |
| | | 500 |
| | 400 | |
| | 300 | |
| | 200 | |
| | 100 | |
| | 0 | |

| GT6041R | | COMPRESSOR | | | | TURBINE | | |
|----------|----------|-------------|-------------|------|------|---------|------|------|
| Turbo PN | CHRA PN | Ind Whl Dia | Exd Whl Dia | Trim | A/R | Whl Dia | Trim | A/R |
| 731377-2 | 730496-1 | 105.7mm | 141.2mm | 56 | 1.05 | 129.5mm | 84 | 1.25 |

