

- Forged, fully-machined compressor wheel featuring next generation aerodynamics
- Dual ball bearing, oil & water-cooled CHRA
- Free float, non-wastegated turbine housing
- Ported shroud compressor housing to increase surge resistance
- Outline interchangeable with GT3582R
- GTX3582R is sold without turbine housing, includes CHRA & compressor housing. Turbine housing kits are available

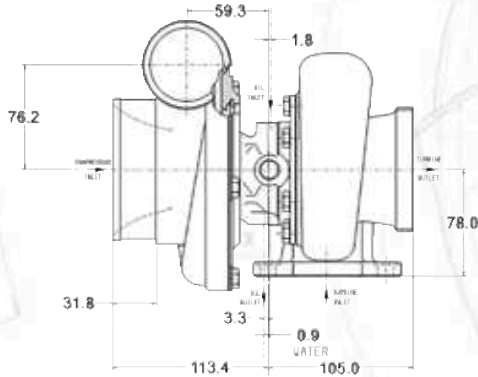

Component	INLET		OUTLET	
	Page	Diagram	Page	Diagram
Compressor	82	33	82	24
Turbine	See Note		See Note	
Oil	84	11	84	18
Water	86	13	86	13

GTX3582R		COMPRESSOR				TURBINE		
Turbo PN	CHRA PN	Ind Whl Dia	Exd Whl Dia	Trim	A/R	Whl Dia	Trim	A/R
803715-1	706451-34	62.5mm	82.5mm	58	0.70	68.0mm	84	-

Dimension Note: Turbine Housing Options  
 \* Note: Inlet flange: 83-04; Outlet flange: 85-07  
 † Note: Inlet flange: 83-04; Outlet flange: 86-13  
 ^ Note: Inlet flange: 83-10; Outlet flange: 86-13

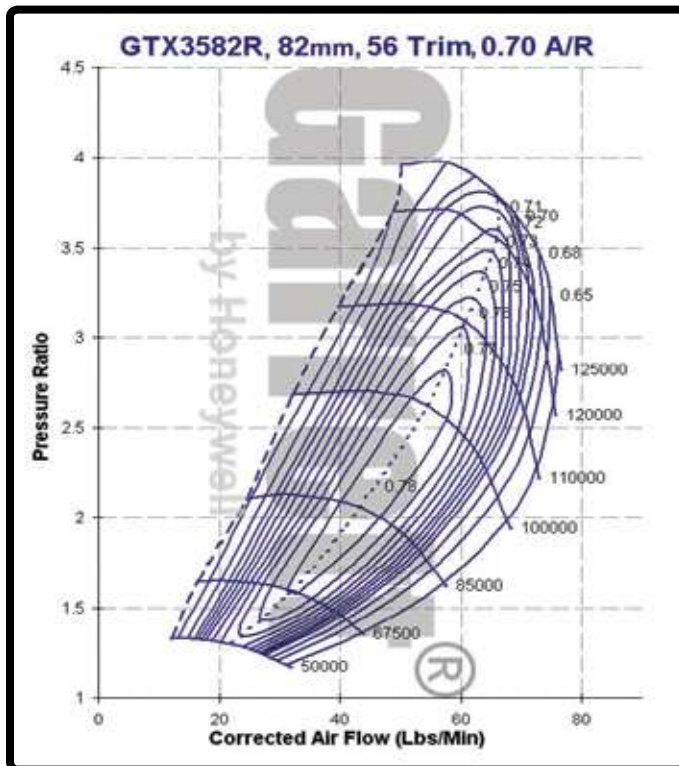

TURBINE HOUSING OPTIONS	
PN	A/R
740902-4*	1.06
740902-5*	0.82
740902-6*	0.63
740902-10 <sup>†</sup>	1.06
740902-11 <sup>†</sup>	0.82
740902-12 <sup>†</sup>	0.63
740902-16 <sup>^</sup>	1.06
740902-17 <sup>^</sup>	0.82
740902-18 <sup>^</sup>	0.63



**DISPLACEMENT 2.0L - 4.5L**

**HORSEPOWER 450 - 750**

2000
1900
1800
1700
1600
1500
1400
1300
1200
1100
1000
900
800
700
600
500
400
300
200
100
0

