

- Forged, fully-machined compressor wheel featuring next generation aerodynamics
- Dual ball bearing, oil & water-cooled CHRA
- Free float, non-wastegated turbine housing
- Optional turbine housings with T4 or diesel turbine inlet flange
- Ported shroud compressor housing to increase surge resistance
- Outline interchangeable with ball bearing GT4294R
- GTX4294R is sold without turbine housing, includes CHRA & compressor housing. Turbine housing kits are available

FLANGE	INLET		OUTLET		
	Component	Page	Diagram	Page	Diagram
Compressor	82	37	82	07	
Turbine	See Note		See Note		
Oil	84	17	84	08	
Water	86	14	86	14	

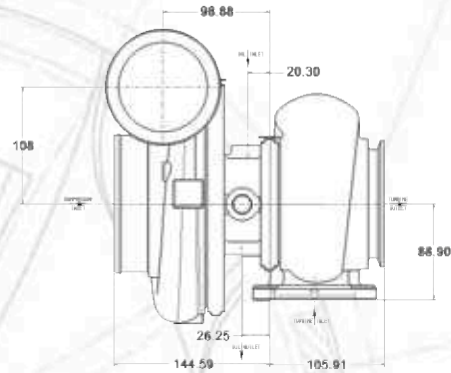

GTX4294R		COMPRESSOR				TURBINE		
Turbo PN	CHRA PN	Ind Whl Dia	Exd Whl Dia	Trim	A/R	Whl Dia	Trim	A/R
800269-1	451888-43	70.3mm	94.0mm	56	0.60	82.0mm	84	-

TURBINE HOUSING OPTIONS	
PN	A/R
757707-1*	1.01
757707-2*	1.15
757707-3*	1.28
757707-4*	1.44
757707-10 ⁺	1.01
757707-9 ⁺	1.15

GTX

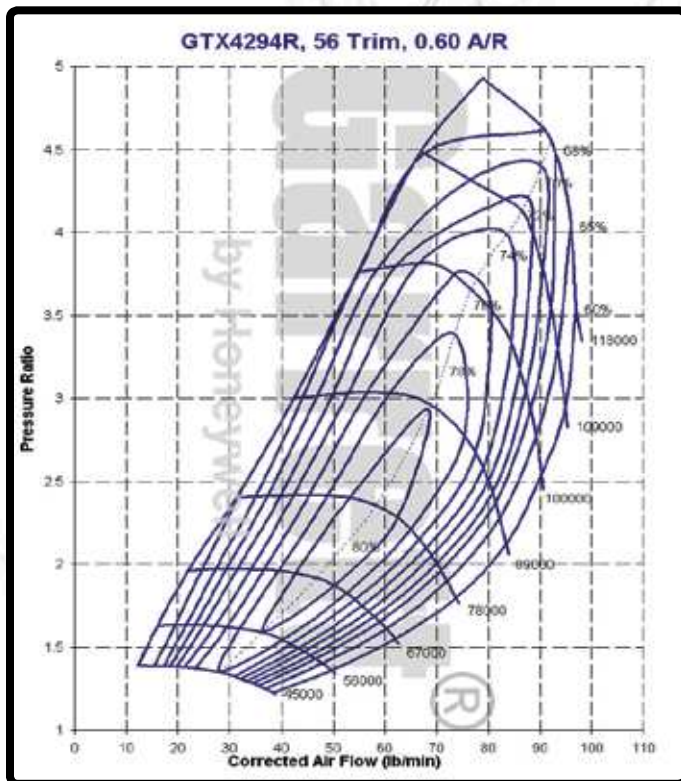

*Note: inlet flange: Page - 84 Diagram - 03
⁺Note: inlet flange: Page - 84 Diagram - 05

