

- Forged, fully-machined compressor wheel featuring next generation aerodynamics
- Dual ball bearing, oil & water-cooled CHRA
- Free float, non-wastegated turbine housing
- Ported shroud compressor housing to increase surge resistance
- Outline interchangeable with the ball bearing GT4508R
- GTX4508R is sold without turbine housing, includes CHRA & compressor housing. Turbine housing kits are available

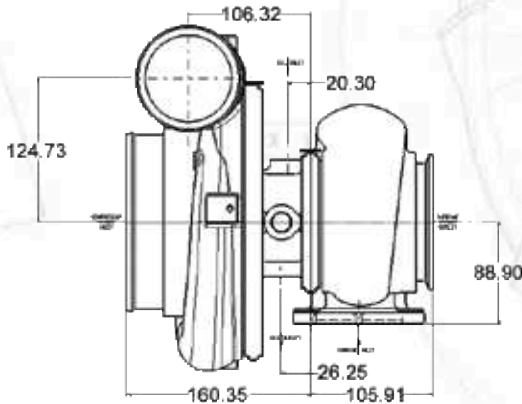

Component	INLET		OUTLET	
	Page	Diagram	Page	Diagram
Compressor	82	38	82	30
Turbine	See Note		See Note	
Oil	84	17	84	08
Water	86	14	86	14

DISPLACEMENT 2.0L - 8.0L

HORSEPOWER 700 - 1250



GTX

GTX4508R		COMPRESSOR				TURBINE		
Turbo PN	CHRA PN	Ind Whl Dia	Exd Whl Dia	Trim	A/R	Whl Dia	Trim	A/R
800270-1	451888-45	79.8mm	108.0mm	55	0.69	87.0mm	85	-

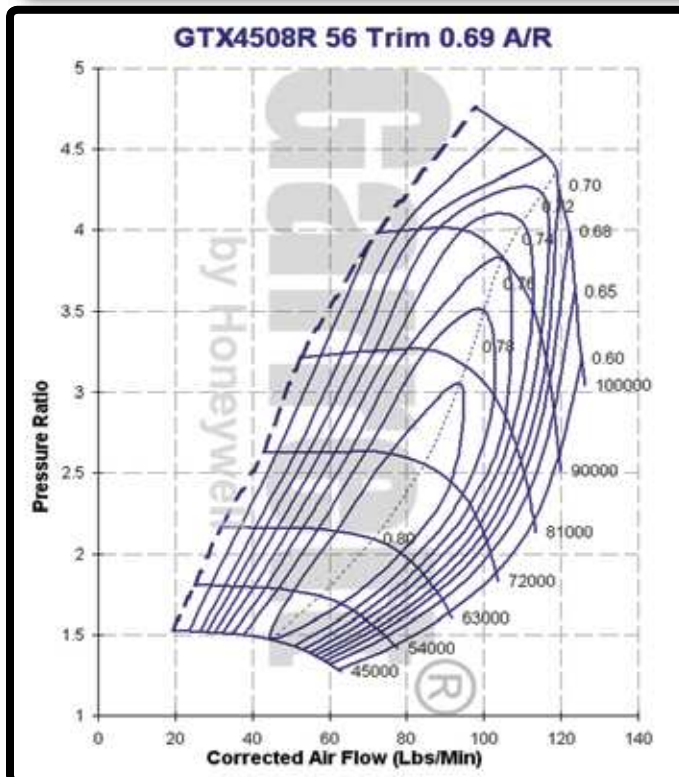

TURBINE HOUSING OPTIONS	
PN	A/R
757707-5	1.01
757707-6	1.15
757707-7	1.28
757707-8	1.44

